

CONTACT IMAGE SENSOR

H2R12

SHEC SHANDONG HUALING ELECTRONICS CO.,LTD.

Beiyang Building, Torch Road, Hi-Tech. IDZ

Weihai Shandong, China

Tel: 86-631-568-8012

Fax: 86-631-568-4988

E-mail: shec@63169.net

Description

This specification is applied to H2R12 Contact Image Sensor module (CIS).

1. Scope

This H2R12 is a CIS consists of a Rod Lens Array, a LED light source array and an array of linear MOS image sensor.

2. Outline

Item	Specification	Note
Scanning width	12 mm	
Sensor element density	200 DPI	
Effective number of sensor elements	96 elements	
Scanning speed	0.125 msec/line	
Clock speed	1.5 MHz	
Rod lens array	Single row	
Light source	$\lambda_p = 660 \text{ nm} \pm 20 \text{ nm}$ 20mA x 2	LED At least two LED vendors.
Power supply	+5V x 60mA	
Data output	1 analog output	Synchronous
Block diagram	Figure 5	
Dimensions	Figure 1	

3. Image Data Output Characteristics (Ta = 25°C)

The shipment test of SHEC is done on the condition of this table.

Item	Symbol	Specification	Note
DC supply voltage	VDD	+5.0V	Detector, Logic
	I _{LED}	+(10~20mA) x 2	LED Note 1
White image target		0.05 ~ 0.09 OD	
Timing diagram		Figure 6	
Dark output minimum	V _{dmin}	1,200 ± 200 mV	4.1
White output maximum	V _{pmax}	800 ± 100 mV	4.2
Dark output	U _d	Less than V _{pmax} /16	4.3
White output uniformity	U _{Ep}	Less than 50%	4.4
MTF		More than 20%	4.5 71.37lppi
Linearity Uniformity	LU	Less than 5%	4.6

Note 1) SHEC shipping test equipment has 68~100-Ohm resistors, MOS transistor and 10-Ohm resistor at GLED1 and GLED2 (CIS connector pin #6 and #7) as shown below. Depending on the customer measurement methods and conditions, the U_{Ep} value would be better than above value.

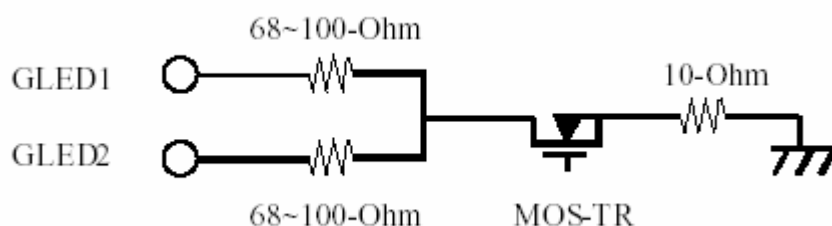

The output level of image signal like white and dark and MTF is defined at the point of “ts” which described in section 6.

A test target is set on the reading position described Figure 1.

4.1 V_{dmin}

As shown in Figure 2, V_{dmin} is the minimum in the dark output signal (turning off the LED). Every other parameters are defined by V_{dmin} as a reference.

4.2 V_{pmax}

As shown in Figure 2, V_{pmax} is the maximum white output signal and is defined by:

$$V_{pmax} = \text{MAX}[V_p(n)]$$

V_p(n) is the output signal of the nth pixel using a white image target.

4.3 U_d

As shown in Figure 2, U_d is the output signal in the dark (turning off the LED) and is defined by;

$$U_d = V_{dmax} - V_{dmin}$$

V_{dmax} is the maximum output signal of the nth pixel in the dark

V_{dmin} is the minimum output signal of the nth pixel in the dark

4.4 UEp

UEp is the white output non-uniformity with dark signal subtracted and is defined by:

$$U_{Ep} = ((V_{Epmax} - V_{Epmin}) / (V_{Epmax})) \times 100\%$$

$V_{Epmax} = \text{MAX}[V_{Ep}(n)]$; is the maximum effective output signal

$V_{Epmin} = \text{MIN}[V_{Ep}(n)]$; is the minimum effective output signal

$V_{Ep}(n)$ is the effective output signal of every pixel and is defined by:

$$V_{Ep}(n) = V_p(n) - V_d(n)$$

4.5 MTF

MTF is defined by:

$$MTF = \text{MIN}\{ [(V_{max} - V_{min}) / V_{Ep}] \} \times 100\%$$

V_{max} is the maximum output signal using the MTF image target

V_{min} is the minimum output signal using the MTF image target

V_{Ep} is the effective output signal .

4.6 Linearity Uniformity

LU is measured following procedure and defined;

Step1. Test Target

The white image target is used as a test target. This target must not be moved while this test is being operated.

Step2. LED adjustment

T_{ir} should be adjusted according to Figure 6 procedure.

Step3. Dark and White correction

Dark and White correction must be done for every each pixel.

Step4. LED turn on time set

T_{ir} should be changed as following;

$$T_{ir}/2$$

Step5. Compute LU

$$LU = \sqrt{D_{gave} - D_{gextm}}$$

D_{gave} is the average of $V_p(n)$. $V_p(n)$ should be got more than 8 times sampling.

Step6. LED turn on time set

T_{ir} should be changed as following and compute LU regarding to Step5; $T_{ir}/4$

Step7. LED turn on time set

T_{ir} should be changed as following and compute LU regarding to Step5; $T_{ir}/8$

4.7 For the best performance two points correction (dark and white) is strongly recommended.

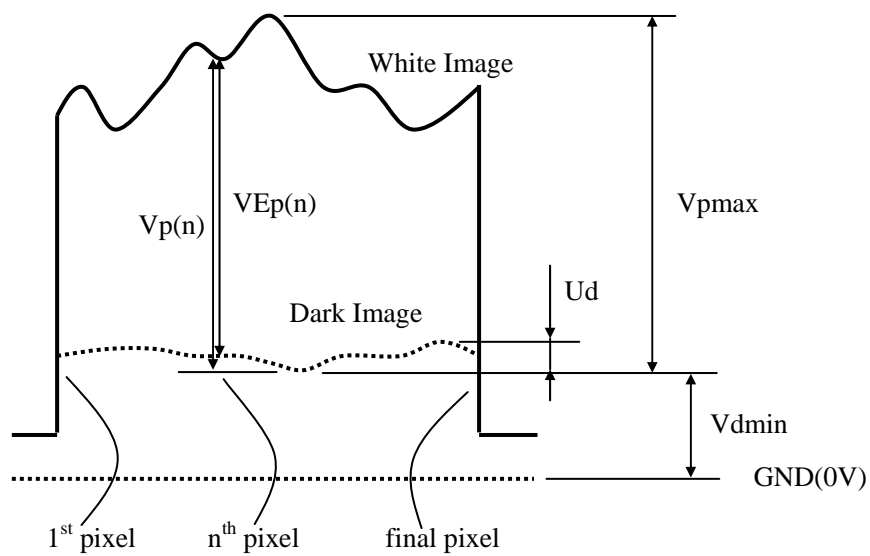

Figure 2. Output Signals Waveform

4. Maximum Rating

Item	Symbol	Specification	Note
DC supply voltage	VDD	+5V ± 0.25V	
Input voltage	VIN	0 ~ VDD+0.3V	SI, CLK
Ambient temperature	Ta	0 ~ +50 °C	Operating
		-20 ~ +60 °C	Non-operating
Ambient humidity		10 ~ 90%RH	Avoid a build up condensation
Maximum operating Temperature		65 °C 30minuts MAX	

LED

Parameter	Symbol	Ir	Notes
DC Forward Current	IF	20 mA	
Pulse Forward Current	IFP	35 mA	Note 1
DC Reverse Voltage	VR	5V	

Note 1) Maximum pulse width duty have to be less than 33%.

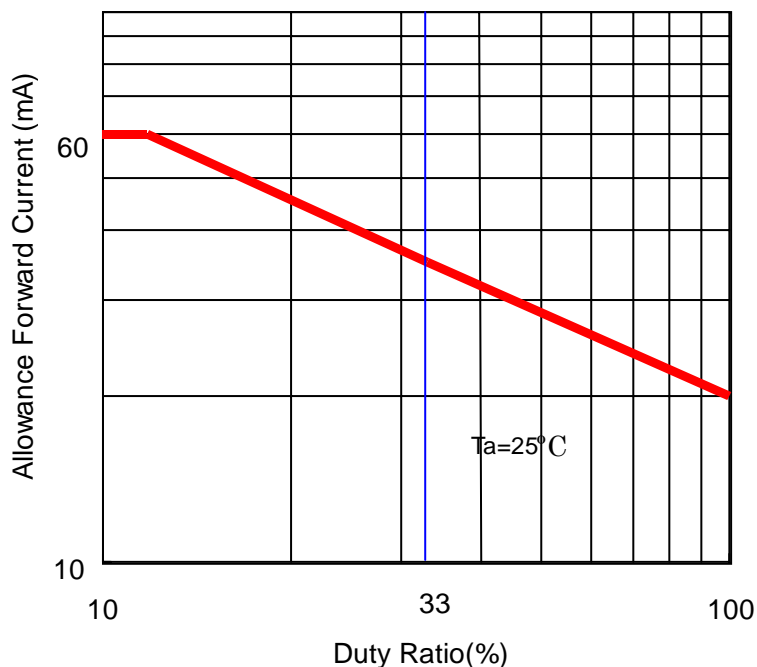

Figure 3. Duty Ratio vs Allowable Forward Current

5. Electrical Characteristics (Ta = 25 °C)

Item	Symbol	Condition	Specification			Unit
			Min.	Typ.	Max.	
DC supply Voltage	VDD	GND reference	4.75	5.0	5.25	V
DC Supply Current	IDD	VDD = 5V		27.0	60.0	mA
LED Forward Voltage	VF	IF=20mA For each LED		1.8	2.6	V
Input voltage (Note 1)	VIH	SI,CLK	3.7			V
	VIL				1.4	V
Input Current (Note 1)	IIH	SI,CLK			±0.1	μA
	IIL				±4	μA
Clock frequency (Note 2)	f	CLK	0.8	1.5	1.8	MHz
Clock pulse duty		tw(T)/to; to=1/f	48	50	52	%
SI delay time	td1	SI-CLK	30	40	to/2	ns
	td2	SI-CLK	30	40	to/2	ns
Data output stability time	ts1	CLK-SIG	0		50	ns

(Note 1) 74HC244 or equivalent is recommended for input signal.

(Note 2) Clock frequency(f) and Scanning speed(Tss) have the relation as following formula.

$$f > (n + d) / Tss$$

f: Clock frequency (MHz)

n: pixel Number of CIS (96 pixels)

d: 88pixels (Dummy pixel Number)

tss: Scanning speed

Clock frequency Min. 0.5MHz (Sensor IC Spec.)

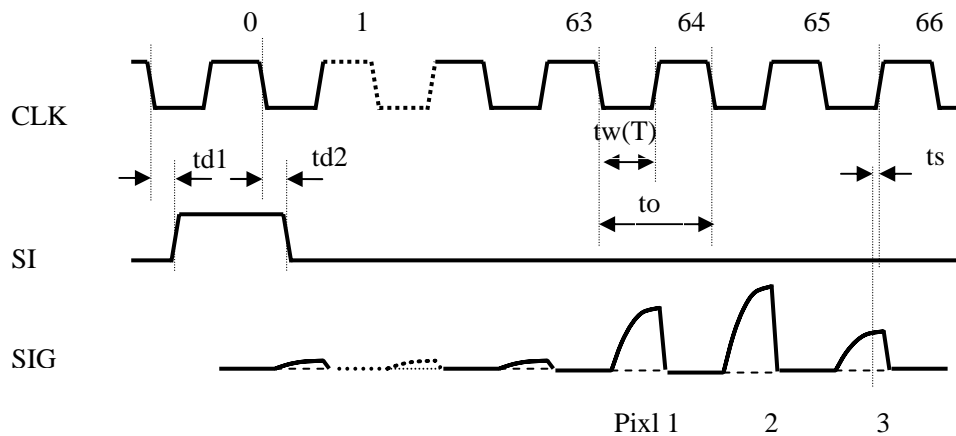

The each pixel's reset time or the blank time should not be used as the reference level.

Figure 4. Timing Diagram

6. Reliability

The following table satisfies the reliability when the CIS is operated continuously under standard operating conditions as specified in section 4.

Item	Variable Amount (%)	Note
White output (Vp)	Initial level +10% -30%	1000Hr
	Initial level +10% -50%	5000Hr

7. Precautions before use:**8.1 Glass surface**

The Glass surface should be kept clean. Don't wipe the glass surface with hand. Don't use the CIS module in a dust-polluted environment. If the glass surface gets dirty, wipe the glass surface gently with a clean cloth soaked in alcohol. The glass surface should be wiped very carefully.

8.2 Extracting / Inserting the connector

The maximum number of times that the connector should be extracted and connected is 10. If the connector is inserted / extracted more than 10 times, the connector 'burrs' will be eroded, thereby making the connector ineffective.

8.3 Stable operation

(1) The connector pins should not be touched by bare hand or electrostatic charge materials.

(2) Noise

- a. Insert a low frequency noise suppressing capacitor (100uF) between VDD (+5V) and GND. A high frequency noise suppressing capacitor is already integrated into the circuit.
- b. Ensure that the sensor connecting cables are 30cm or less in length. The CLK and GND, SIG and GND and VLED and GLED respectively from form twisted cable pairs.

(3) Latch up

When the supply voltage is higher than the absolute maximum, latch up will cause the sensor to break, even if the voltage is caused by a surge. If the current varies rapidly in the external in the external circuit, or when the power is turned on an off very frequently, ensure that the voltage o each terminal does not exceed the values indicated in below.

(4) LED circuit

As shown in Figure.5 LED circuit has not any resistance. Be careful no to connect the LED circuit to power supply directory without current limit resistors.

(5) Absolute maximum ratio

Item	Symbol	Condition	Specification		Unit
			Min	Max	
Supply Voltage	VDD	GND reference	-0.3	+6.5	V
Input voltage	Vin	SI,CLK	GND-0.3	VDD+0.3	V

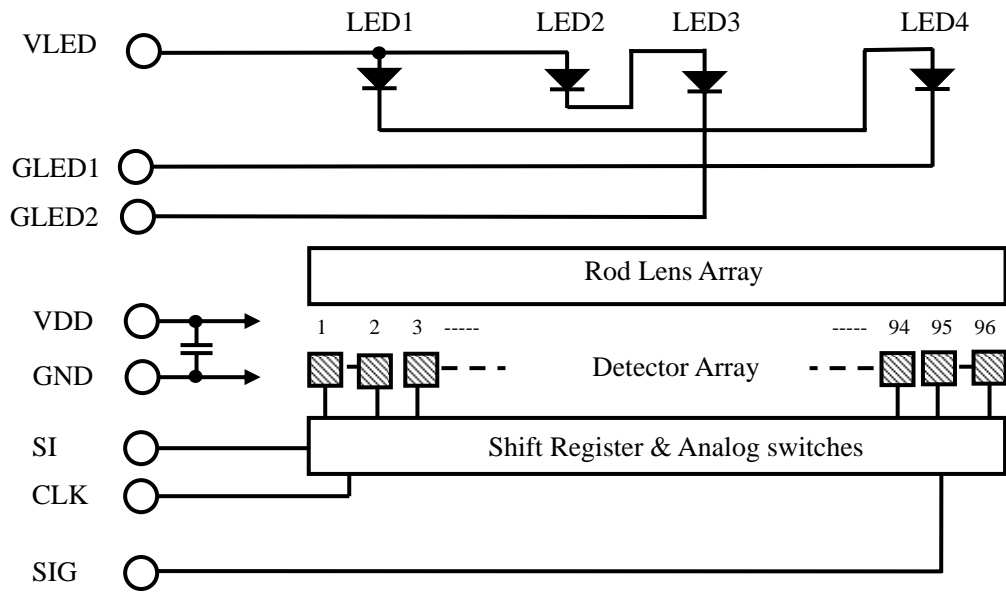
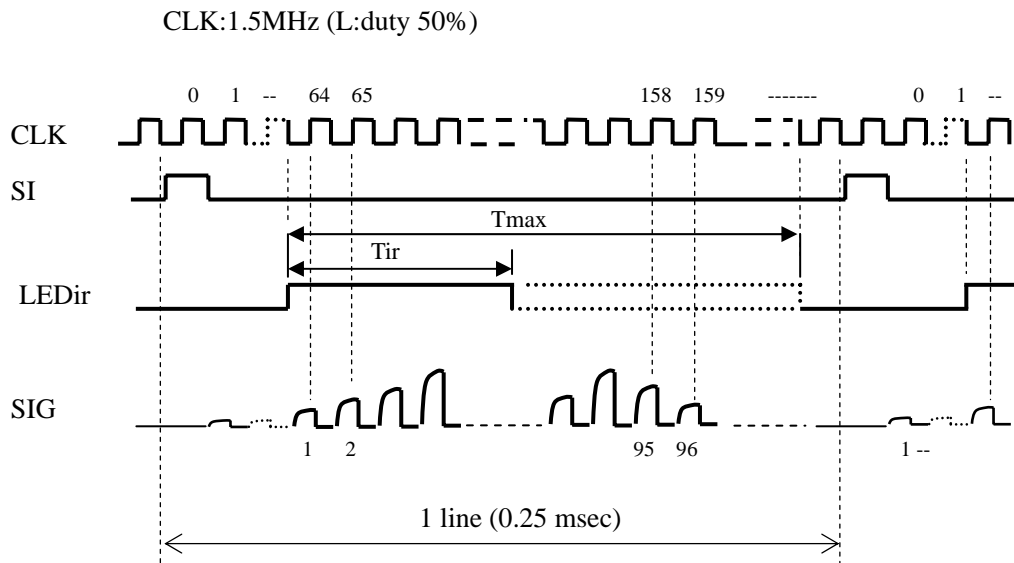

Figure 5. Block Diagram



This is the example for Ir mono-color application. Refer the adjustment flow chart at Figure 7.

Figure 6. Timing Diagram

(This is the SHEC shipping test condition)

After 96th SIG, There are 24bits dummy output.

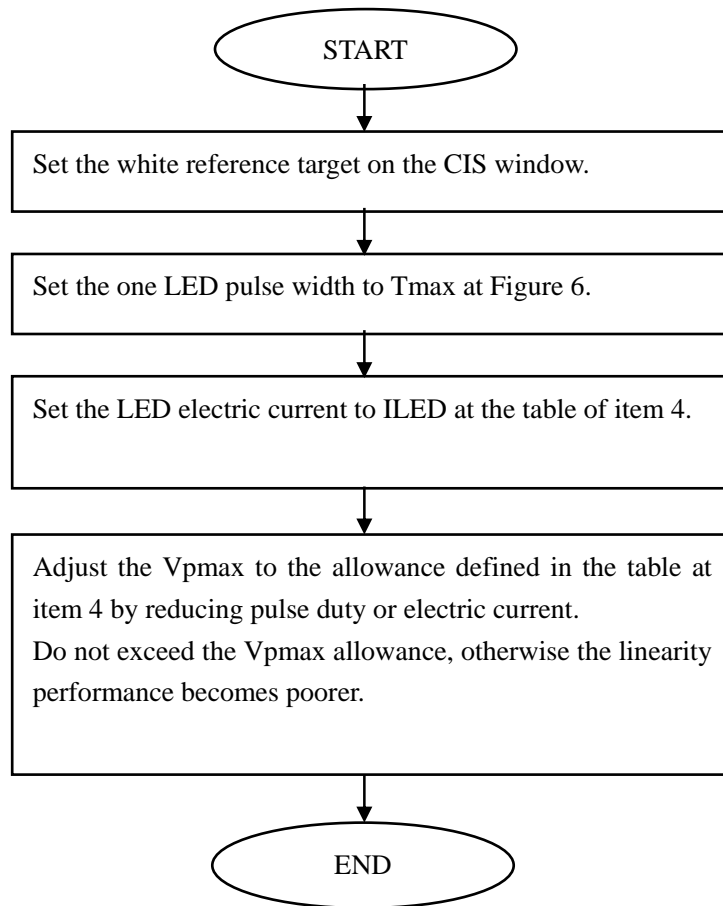

Figure 7. Flow chart for Mono-Color Adjustment

Figure 8. Typical Performance Curve
Unless otherwise specified, Ta=25°C

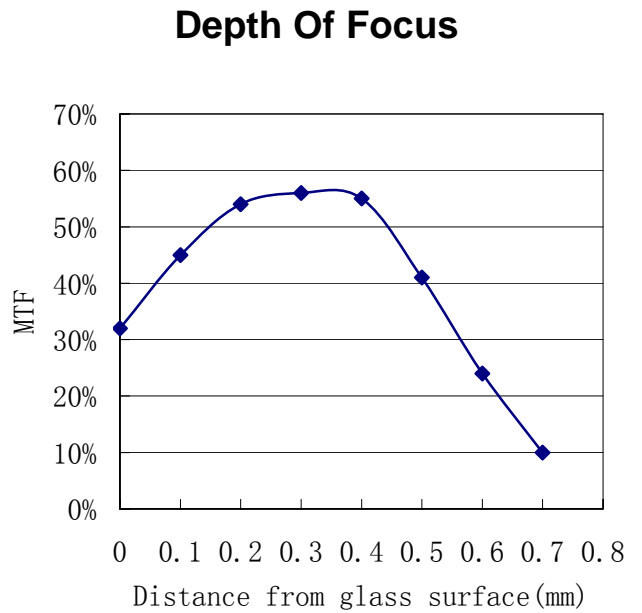
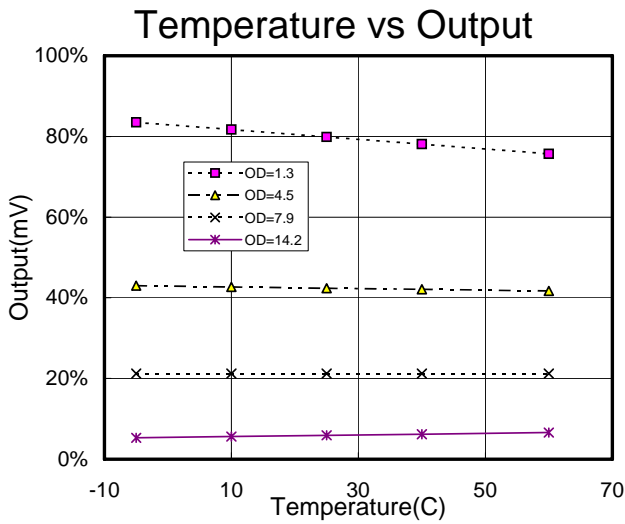
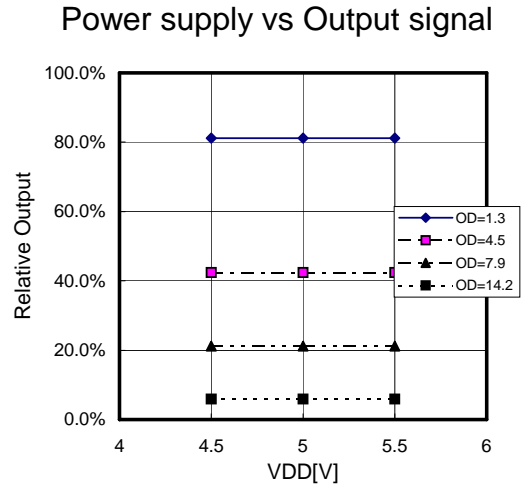
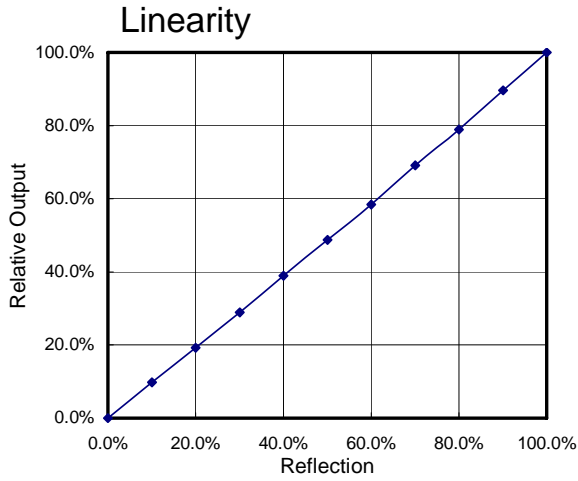
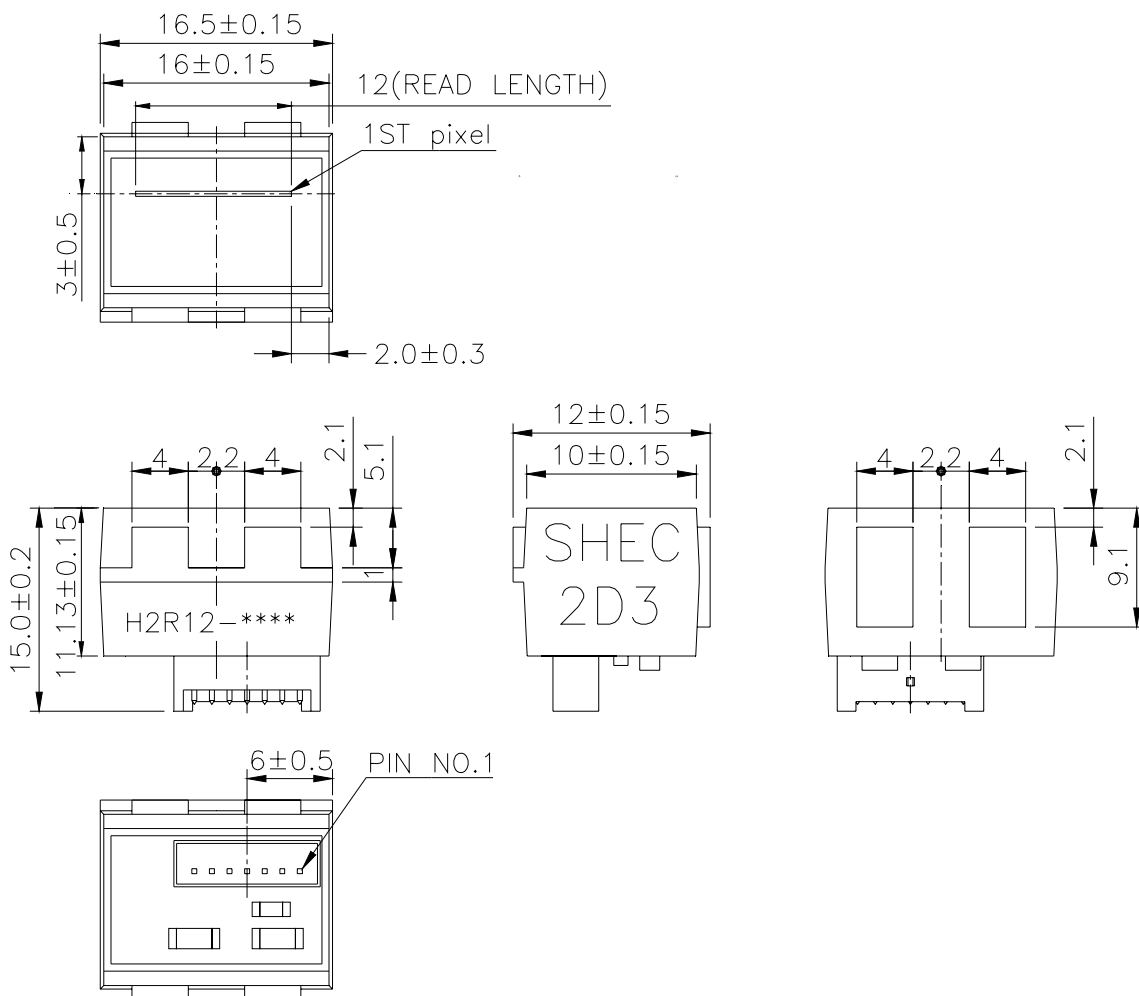

Figure 1. Dimensions



NOTE:

1.CONNECTOR:IL-Z-7P-S125T3-E(JAE) OR EQUIVALENT

SOCKET:IL-Z-7S-S125C3(JAE) OR EQUIVALENT

2.CIS TYPE AND LOT NUMBER ARE PRINTED ON THE SIDE OF THE SENSOR FRAME.

H2R12-**** SHEC
2 D 3
CIS TYPE (2002)(DEC.)(3)

date	10	11	12	13	14	15	16	17	18	19	20
	A	B	D	E	F	H	J	K	L	M	N
date	21	22	23	24	25	26	27	28	29	30	31
	O	P	R	S	T	U	V	W	X	Y	Z

PIN CONNECTION

PIN NO.	NAME
1	SIG
2	GND
3	VDD and VLED
4	SI
5	CLK
6	GLED1
7	GLED2

3.The tolerance that is not designated is ± 0.1 mm