

1. Description

This specification is applied to EN48N thermal print head.

2. Scope

The EN48N is a thermal print head which has heat elements which produce 384 dots with 8 dots/mm by means of a high density thick film process. It also includes C-MOS ICs; Which operate as 384 bits shift-registers, latches and switching transistors to drive heat elements.

3. Outline

Item	Specification	Note
Dimension	Fig.5	
Schematic diagram	Fig.3	
Pin assignment	Table.3	
Print width	48 mm	
Number of heaters	384 dots	
Heater resolution	8 dots/mm	
Heater pitch	0.125 mm	
Printed dot dimension	0.11mm×0.10 mm	
Heater resistance	$\bar{R} = 176 \Omega \pm 4\%$ $R = \bar{R} \pm 15\%$	
Specifications for driver ICs	Table.2	
Number of driver ICs	64bits × 6	
Number of data inputs	1 serial input	
Number of strobos	6	
Logic power supply	3.3 V × 18 mA	at 5 MHz
	5.0 V × 30 mA	
Specification for Thermistor	$R_{25}=30K \Omega \pm 5\%$, $B=3,950K \pm 3\%$	Table. 1

4. Maximum ratings

Parameter	Symbol	Specification	Note
Heater energy consumption	Eomax		
		0.20 mJ/dot	1.25 ms/line
Head voltage	VH	8.5 V	Between Connectors
Logic voltage	Vdd	7V	
Environment temperature	Ta	-30 ° C ~ +50 ° C	Operating(The printed optical density is not guaranteed between -30 ° C ~ +5 ° C)
		- 40 ° C ~ +80 ° C	Non-operating
Environment humidity		10 ~ 90%RH	Non-condensing
Maximum operating temperature	Ts	Continuous:65° C 30min. MAX.	Thermistor temp.
		Peak:80° C Thermistor temp.	When 80° C was detected, Printing must be stopped, and wait until 60° C

5. Standard printing conditions

5.1 Vdd = 3.3 -5 V

Parameter	Symbol	Recommended operating conditions	Note
Speed		1.25 ms/line	
		2 inch/sec	
Heater power consumption	Po	0.24 W/dot	$\bar{R} = 176 \Omega$
Heat voltage	VH	7.2 V	Between Connectors
Heater energy consumption	Eo (ts)	5°C 0.16 mJ/dot(0.67 ms)	64 dots simultaneously ON (Note 1)
		25°C 0.13 mJ/dot(0.55 ms)	
		40°C 0.11 mJ/dot(0.46 ms)	
Supply current	Io	36.7mA/dot	$\bar{R} = 176 \Omega$
Timing chart		Fig. 2	
Platen pressure		14.7±1.96 N / TPH	
Platen hardness		40~50deg	
Platen diameter		Φ8 Max.	
Scanning resolution		16 line/mm	
Thermal paper		F24OAC / F220-VP MITSUBISHI PAPER MILL CO., LTD.	
Optical density		1.1 OD Min.	(Note 2)

(Note 1) Supply energy is defined by the following formula.

$$E_o = I_o^2 \bar{R} t_s = \frac{(VH - V_{com})^2 \cdot \bar{R} \cdot t_s}{(\bar{R} + R_{ic})^2}$$

$R_{ic} = 12 \Omega$: Driver IC "ON" resistance

t_s : Strobe pulse width

VH : Head voltage

\bar{R} : Heater average resistance

$V_{com} = 0.3 \text{ V}$

(Note 2) Printed optical density is measured at 10mm intervals after the starting point. Printed optical density is measured by RD-914 reflector optical density meter or equivalent .

6. Life expectancy

The life expectancy under 12.5% printing duty of less at 25° C is defined by the following whichever earlier comes.

Item	Specification	Note
Number of pulses	$1 \times 10^8 \text{ pulses}$	
Run length	50 Km	

7. Warning during use

7.1 Strobe signal

During head power supply ON/OFF sequence ,strokes should be kept "disable".

7.2 Stability of IC operation

Care should be taken for stable operation of driver ICs as indicated bellow. (Fig.1)

(1) If the voltage including surge exceeds maximum rating of driver IC, the TPH may burn out by latch-up. Care should be taken especially when head current changes by strobes or at the ON/OFF sequence. The voltage shall be kept within the following voltage.

VH	: 0V ~ +8.5V
Vdd	: 0V ~ +7V
Other signals	: GND -0.5V ~ Vdd+0.5V

7.3 The heater and driver ICs are electrostatically sensitive. Care should be taken not to touch connectors with hands or an electrostatically charged object. It is recommended that brushes near the head be provided to discharge electrostatic build up.

7.4 On the surface near the heater, do not apply any hard material. The abrasion resistant layer is fragile to mechanical impact.

7.5 Ink dregs adhered to the heater should be wiped off softly with a soft cloth dipped alcohol or detergent. Do not use sandpaper or equivalent.

7.6 Keep hard particles out of the heater surface. Hard particles may scratch the abrasion resistant layer.

7.7 Maximum number of heaters for simultaneous is 192.

7.8 When the printer is on standby, the thermal head (VH) must be switched off.

Fig. 1 Recommend Connection

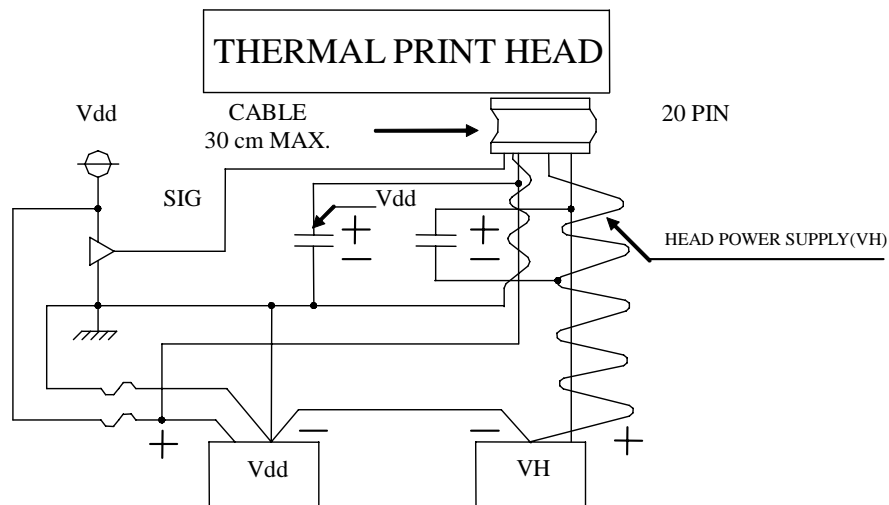

Table. 1 Thermistor

$$R_{25} = 30K\Omega \pm 5\%, B_{CONST} = 3950\text{kelvin} \pm 3\%, R = R_{25}e^{B(1/T - 1/T_{25})}$$

Temperature (° C)	Thermistor Resistance (R)		
	Min .(K Ω)	Typ. (K Ω)	Max. (K Ω)
-40.0	717	843	989
-35.0	535	623	723
-30.0	405	466	535
-25.0	308	352	400
-20.0	238	269	303
-15.0	185	208	232
-10.0	145	161	178
-5.0	113	124	137
0.0	88.7	96.8	105
5.0	69.9	75.7	81.7
10.0	55.4	59.5	63.8
15.0	44.1	47.1	50.1
20.0	35.4	37.5	39.6
25.0	28.5	30.0	31.5
30.0	22.8	24.2	25.5
35.0	18.3	19.6	20.8
40.0	14.9	15.9	17.1
45.0	12.1	13.1	14.1
50.0	9.92	10.8	11.7
55.0	8.16	8.91	9.7
60.0	6.76	7.41	8.12
65.0	5.62	6.2	6.83
70.0	4.7	5.21	5.77
75.0	3.95	4.4	4.9
80.0	3.34	3.74	4.18

Table. 2 C-MOS Driver IC with Vdd = 3.3-5.0V

Table 2.1 Electrical characteristics for driver IC

Absolute maximum ratings for driver ICs.

Parameter	Symbol	Test conditions	Ratings	Unit
Supply voltage	V_{dd}	Surge	0 ~ 7	V
	VH	Surge	0 ~ 10	V
Input voltage for logic	V_{IN}		0 ~ $V_{dd} + 0.5$	V

Recommended operating conditions

Parameter	Symbol	Test conditions	Recommendations			Unit
			Min.	Typ.	Max.	
Supply voltage	V_{dd}		3.0	3.3	5.5	V
	VH	Supply voltage for VH	4.2	5.0	8.5	V
Input voltage for logic	V_{IH}	(Note 1)	$0.7 \times V_{dd}$		V_{dd}	V
	V_{IL}				$0.3 \times V_{dd}$	V
Clock frequency	f_{CLK}	duty 50%			5	MHz

(Note 1) Recommended driver IC is 74HC244 or equivalent.

Table 2.2 Electrical characteristics for driver IC.

Parameter	Symbol	Test conditions	Ratings			Unit
			Min.	Typ.	Max.	
Input current	\overline{LATCH}	(Note 1) I_{IH} $V_{dd} = 5\text{ V}$ $V_{IH} = 5\text{ V}$			3.0	μA
	\overline{STROBE}				55	μA
	\overline{CLOCK}				3.0	μA
	$\overline{DATA IN}$				0.5	μA
	\overline{LATCH}	I_{IL} $V_{dd} = 5\text{ V}$ $V_{IL} = 0\text{ V}$	-3.0			μA
	\overline{STROBE}		-0.5			μA
	\overline{CLOCK}		-3.0			μA
	$\overline{DATA IN}$		-0.5			μA
Output voltage of drivers (Heater supply voltage)	V_{OL}	$I_{OL} = 60\text{mA}$		0.7	0.9	V
Leak current of drivers	I_{LEAK}	$V_{OH} = 7\text{ V}$			1.0	$\mu\text{A/dot}$
Logic supply current	I_{dd}	$f_{CLK} = 5\text{ MHz}$ $SI = 1/2 f_{CLK}$		9.6	30	mA

(Note 1) Each STROBE includes pull-down resistance of $300\text{K}\Omega \pm 50\%$ per IC.

Table 2.3 Switching characteristics for driver ICs.

Parameter	Symbol	Test conditions	Ratings			Unit
			Min.	Typ.	Max.	
Clock frequency	f_{MAX}	cascade			5.0	MHz
Clock pulse width	$tw(T)$		70			ns
Data setup time	$tsu(D)$		40			ns
Data hold time	$th(D)$		40			ns
Latch setup time	$tsu(LA)$		100			ns
Latch pulse width	$tw(LA)$		100			ns
Strobe to driver Output delay time	$td(DO)$				26.0	μs

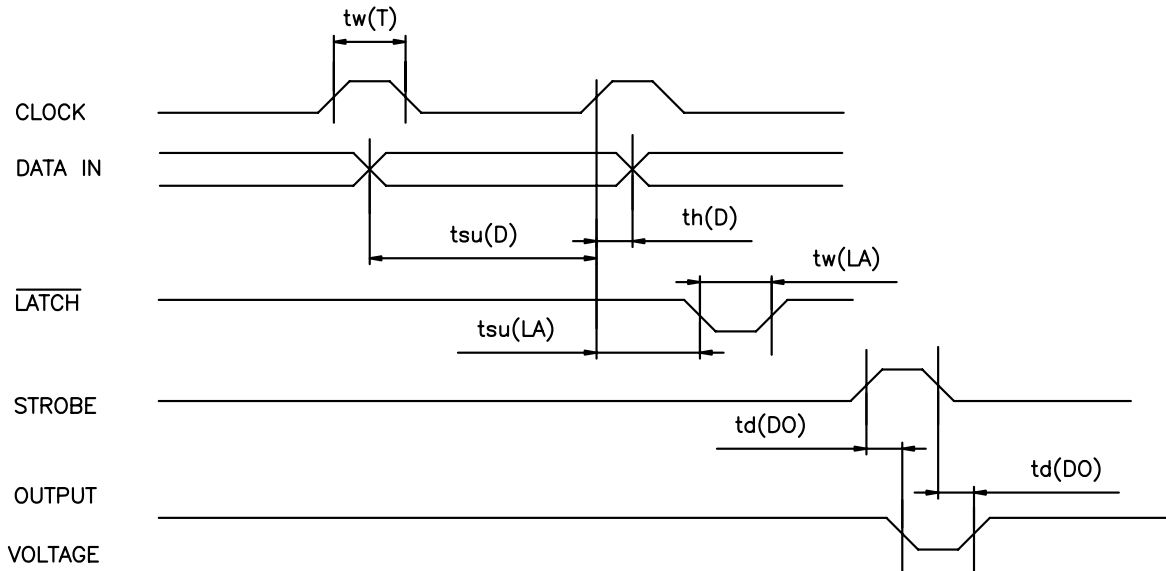

Fig. 2 Thermal Print Head (EN48N) Timing Chart

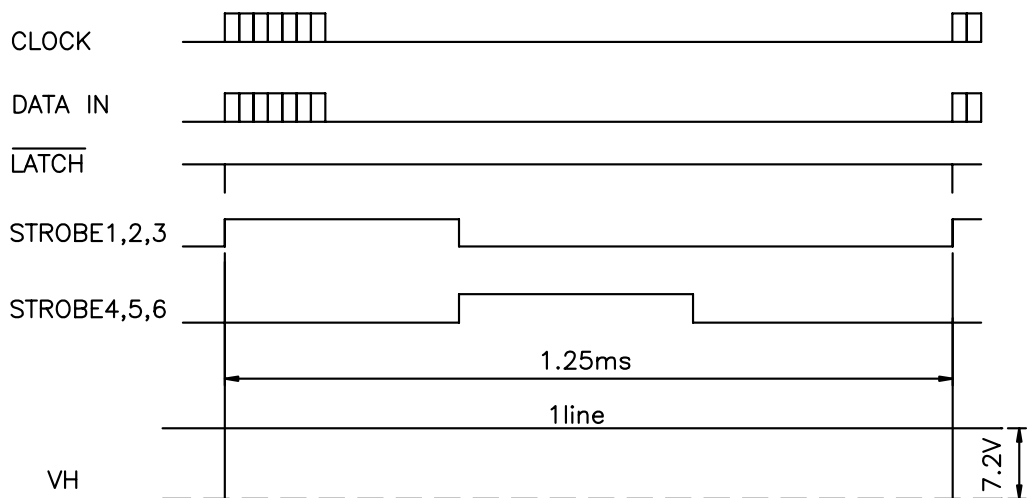

Fig. 3 Schematic Diagram

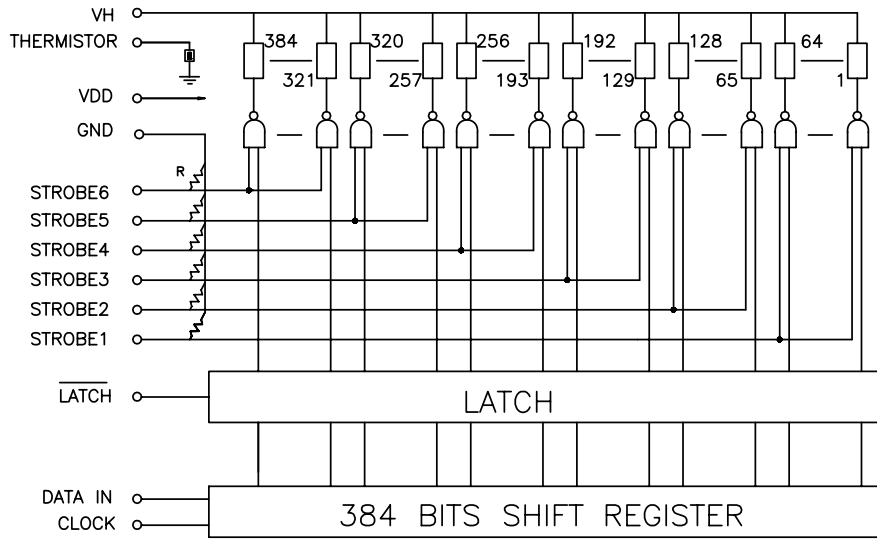

Fig. 4 Cross Section

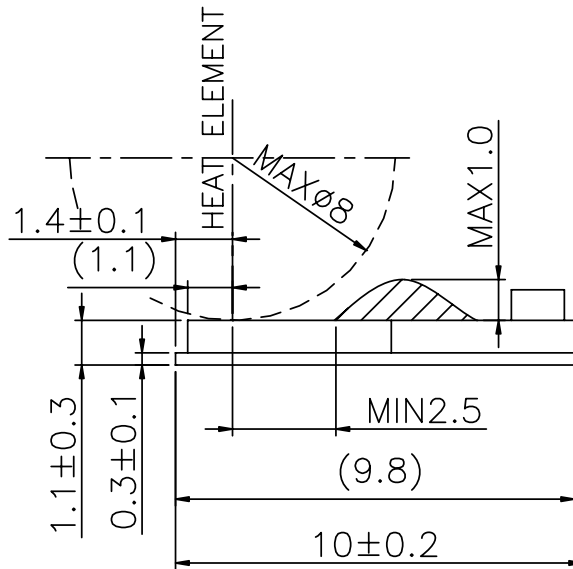
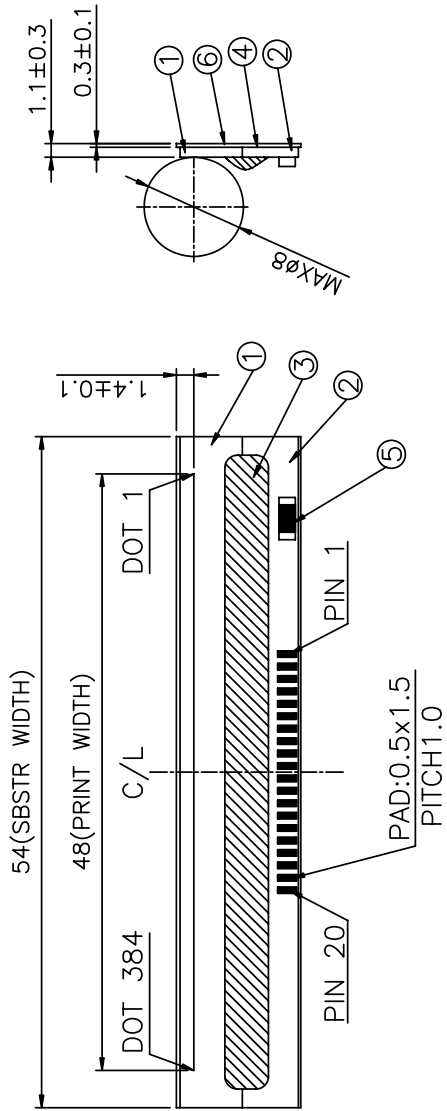

Table. 3 Pin assignment

PIN	NAME	PIN	NAME	PIN	NAME
1	VH	8	STROBE1	15	\overline{LATCH}
2	VH	9	VDD	16	DATA IN
3	GND	10	STROBE2	17	GND
4	GND	11	STROBE4	18	GND
5	GND	12	STROBE5	19	VH
6	STROBE3	13	STROBE6	20	VH
7	THERMISTOR	14	CLOCK	21	

Fig. 5 Dimension



ITEM	DESCRIPTION	MATERIAL	DEF	SUMMARYS
1	SUBSTRATE	CERAMIC	1	
2	CIRCUIT BOARD	FR4	1	
3	EPOXY MOLD		1	
4	ADHESIVE		1	
5	THERMISTOR		1	
6	BASE	stainless steel	1	

NOTE:

1. COMPOSITION OF LOT No. 7 09 (2007) (Sep)
2. THIS MODEL COMPLIES WITH THE RoHS DIRECTIVE

