

Notice: This is not a final specification.

Outline, some parametric limits and figures are subject to change.

# CONTACT IMAGE SENSOR

## H8R108

**SHEC** SHANDONG HUALING ELECTRONICS CO.,LTD.

Torch Road, Hi-Tech. IDZ

Weihai Shandong, China

Tel: 86-631-569-8012

Fax: 86-631-568-4988

E-mail: SHEC@163169.net

### 1. Description

This specification is applied to H8R108 Contact Image Sensor module (CIS).

### 2. Scope

This H8R108 is a CIS consists of a Rod Lens Array, a LED light source and an array of linear MOS image sensor.

### 3. Outline

Item	Specification	Note
Scanning width	108 mm	
Sensor element density	8dot/mm	
Effective number of sensor elements	864 elements	
Scanning speed	0.5 msec/line	
Clock speed	1.75 MHz	
Rod lens array	Single row	
Light source	Red $\lambda_p = 630\text{nm} \pm 15\text{nm}$ 60mA Green: $\lambda_p = 520\text{nm} \pm 15\text{nm}$ 60mA IR: $\lambda_p = 940\text{nm} \pm 20\text{nm}$ 60mA	LED At least two LED vendors.
Power supply	+5V x 40 mA	
Data output	1 analog output	Synchronous
Block diagram	Figure 4	
Dimensions	Figure 1	

**4. Image Data Output Characteristics (Ta = 25°C )**

The shipment test of SHEC is done on the condition of this table.

Item	Symbol	Specification			Note
		Red	Green	IR	
DC supply voltage	VDD	+5.0V			Detector, Logic
LED supply voltage	VLED	<3.0V	<5.0V	<2.0V	LED
LED supply current	ILED	60mA	60mA	60mA	
White image target		0.05 ~ 0.09 OD			
Timing diagram		Figure 5, Figure 7			
Dark output minimum	Vdmin	50~250mV			4.1
White output maximum	Vpmax	370±50mV	230±50mV	370±50mV	4.2
Dark output	Ud	Less than Vpmax/4			4.3
White output uniformity	UEp	Less than 50%			4.4
MTF		20% MIN	30%MIN	5%MIN	4.5 71.37 lppi
Linearity Uniformity	LU	Less than 6%			4.6

The output level of image signal like white and dark and MTF is defined at the point of “ts1” which described in section 6.

A test target is set on the reading position described Figure 1..

**4.1 Vdmin**

As shown in Figure 2, Vdmin is the minimum in the dark output signal (turning off the LED).

Every other parameters are defined by Vdmin as a reference.

**4.2 Vpmax**

As shown in Figure 2, Vpmax is the maximum white output signal and is defined by:

$$Vpmax=MAX[Vp(n)]$$

Vp(n) is the output signal of the n-th pixel using a white image target.

**4.3 Ud**

As shown in Figure 2, Ud is the output signal in the dark (turning off the LED) and is defined by;

$$Ud=Vdmax-Vdmin$$

Vdmax is the maximum output signal of the n-th pixel in the dark

Vdmin is the minimum output signal of the n-th pixel in the dark

**4.4 UEp**

UEp is the white output non-uniformity with dark signal subtracted and is defined by:

$$UEp = ((VEpmax - VEpmi) / (VEpmax)) \times 100\%$$

$VEpmax = \text{MAX}[VEp(n)]$ ; is the maximum effective output signal

$VEpmin = \text{MIN}[VEp(n)]$ ; is the minimum effective output signal

$VEp(n)$  is the effective output signal of every pixel and is defined by:

$$VEp(n) = Vp(n) - Vd(n)$$

#### 4.5 MTF

MTF is defined by:

$$MTF = \text{MIN}\{ [(Vmax - Vmin) / VEp] \} \times 100\%$$

$Vmax$  is the maximum output signal using the MTF image target

$Vmin$  is the minimum output signal using the MTF image target

$VEp$  is the effective output signal .

#### 4.6 Linearity Uniformity

LUg is measured following procedure and defined;

##### Step1. Test Target

The white image target is used as a test target. This target must not be moved while this test is being operated.

##### Step2. LED adjustment

$Tred$ ,  $Tgrn$  should be adjusted according to Figure 6 procedure.

##### Step3. Dark and White correction

Dark and White correction must be done for every each pixel.

##### Step4. LED on time set

$Tred$ ,  $Tgrn$ ,  $Tir$  should be changed as following;

$$Tred/2, Tgrn/2, Tir/2$$

##### Step5. Compute LUg

LUg should be computed for each color as;

$$LUg = (Dgave - Dgextm) /$$

$Dgave$  is the average of  $Vg(n)$ .  $Vg(n)$  should be got more than 8 times sampling.

##### Step6. LED on time set

$Tred$ ,  $Tgrn$ ,  $Tir$  should be changed as followed and compute LUg regarding to Step5;

$$Tred/4, Tgrn/4, Tir/4$$

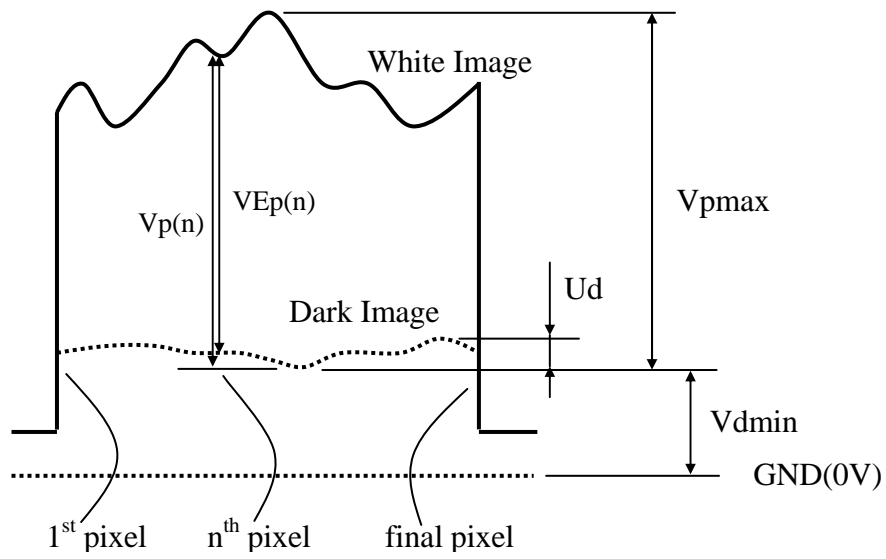
##### Step7. LED on time set

$Tred$ ,  $Tgrn$  should be changed as followed and compute LUg regarding to Step5;

$$Tred/8, Tgrn/8, Tir/8$$

#### 4.7 Correction of Dark and White uniformity

For the best performance two points correction (dark and white) is strongly recommended.



**Figure 2. Output Signals Waveform**

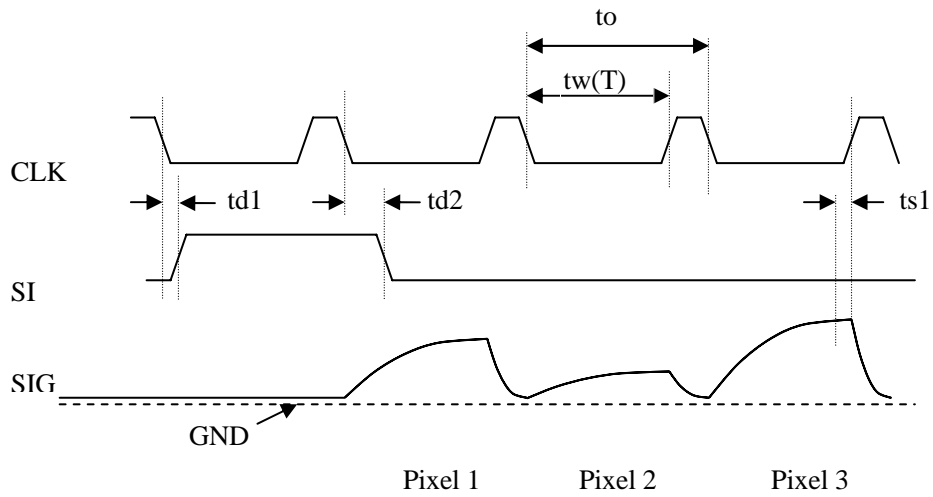
### 5. Maximum Rating

Item	Symbol	Specification	Note
DC supply voltage	VDD	+5V ± 0.25V	
Input voltage	VIN	-0.2 ~ VDD+0.3V	SI, CLK
Ambient temperature	Ta	0 ~ +50 °C	Operating
		-20 ~ +60 °C	Non-operating
Ambient humidity		10 ~ 90%RH	Avoid a build up condensation
Maximum operating Temperature		65 °C 30minuts MAX	

### 6. Electrical Characteristics (Ta = 25 °C)

Item	Symbol	Condition	Specification			Unit
			Min.	Typ.	Max.	
DC supply Voltage	VDD	GND reference	4.75	5.0	5.25	V
DC Supply Current	IDD	VDD = 5V		30	40	mA
LED forward Voltage	VFred	IF=60mA	2.1	2.3	2.5	V
	VFgen	IF=60mA	3.6	4.0	4.4	V
	VFir	IF=60mA	1.4	1.5	1.6	V
Input voltage (Note 1)	VIH	SI,CLK	3.7			V
	VIL				1.4	V
Input Current (Note 1)	I <sub>IH</sub>	SI,C			±0.1	μA
	I <sub>IL</sub>	LK			±4	μA
Clock frequency	f	CLK	1.65	1.75	1.85	MHz
Clock pulse duty		tw(T)/to; to=1/f	73	75	77	%
SI delay time	td1	SI-CLK	30	40	to/2	ns
	td2	SI-CLK	30	40	to/2	ns
Data output stability time	ts1	CLK-SIG	0		30	ns

(Note1) 74HC244 or equivalent is recommended for input signal.



The each pixel's reset time or the blank time should not be used as the reference level.

**Figure 3. Timing Diagram**

## 7. Reliability

The following table satisfies the reliability when the CIS is operated continuously under standard operating conditions as specified in section 4.

Item	Variable Amount (%)	Note
White output (Vp)	Initial level +10% -30%	1000Hr
	Initial level +10% -50%	5000Hr

**8. Precautions before use:****8.1 Glass surface**

The glass surface should be kept clean. Don't wipe the glass surface with hand. Don't use the CIS module in a dust-polluted environment. If the glass surface gets dirty, wipe the glass surface gently with a clean cloth. The glass surface should be wiped very carefully.

**8.2 Extracting / Inserting the connector**

The maximum number of times that the connector should be extracted and connected is 10. If the connector is inserted / extracted more than 10 times, the connector 'burrs' will be eroded, thereby making the connector ineffective.

**8.3 Stable operation**

(1) The connector pins should not be touched by bare hand or electrostatic charge materials.

**(2) Noise**

- a. Insert a low frequency noise suppressing capacitor(100uF) between VDD(+5V) and GND. A high frequency noise suppressing capacitor is already integrated into the circuit.
- b. Ensure that the sensor connecting cables are 30cm or less in length. The CLK and GND, SIG and GND and VLED and GLED respectively from form twisted cable pairs.

**(3) Latch up**

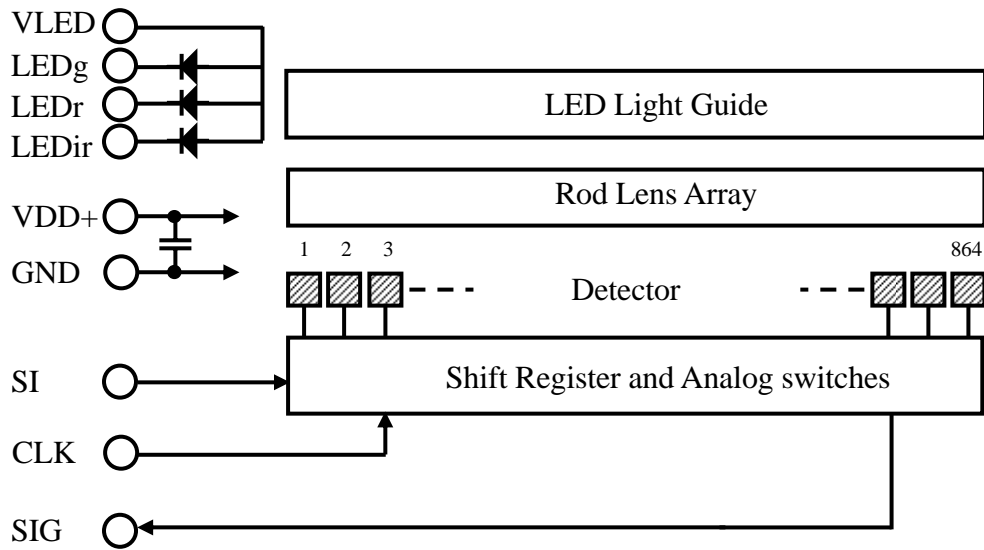
When the supply voltage is higher than the absolute maximum, latch up will cause the sensor to break, even if the voltage is caused by a surge. If the current varies rapidly in the external circuit, or when the power is turned on an off very frequently, ensure that the voltage of each terminal does not exceed the values indicated in below.

**(4) LED circuit**

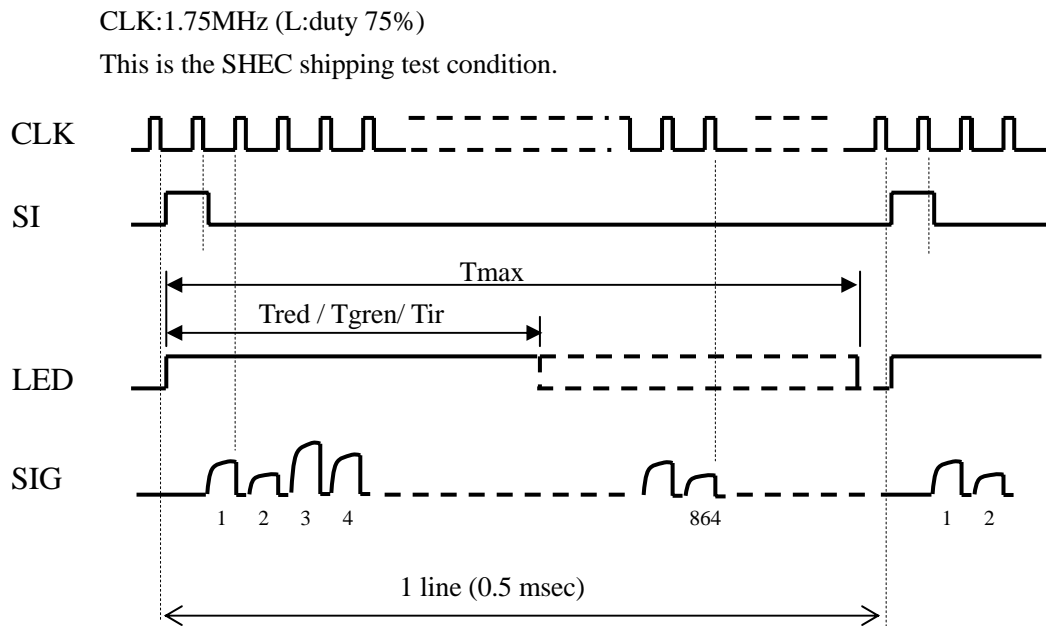
As shown in Figure.4 LED circuit has not any resistance. Be careful not to connect the LED circuit to power supply directly without current limit resistors.

**(5) Absolute maximum ratings**

Item	Symbol	Condition	Specification		Unit
			Min	Max	
Supply Voltage	VDD	GND reference	-0.3	+6.5	V
Input voltage	Vin	SI,CLK	GND-0.3	VDD+0.3	V

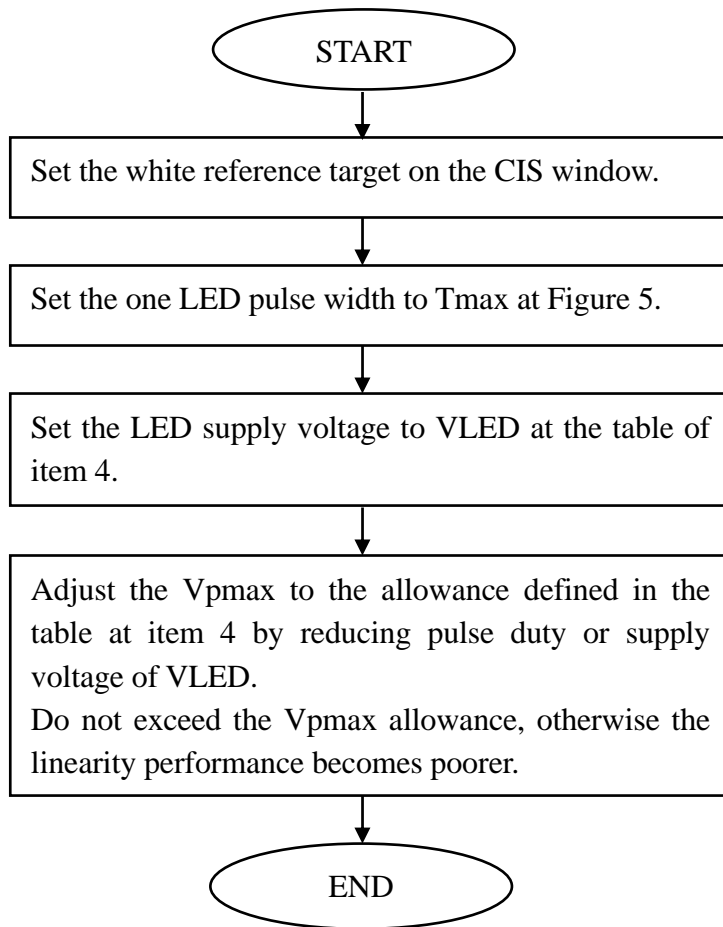


**Figure 4. Block Diagram**

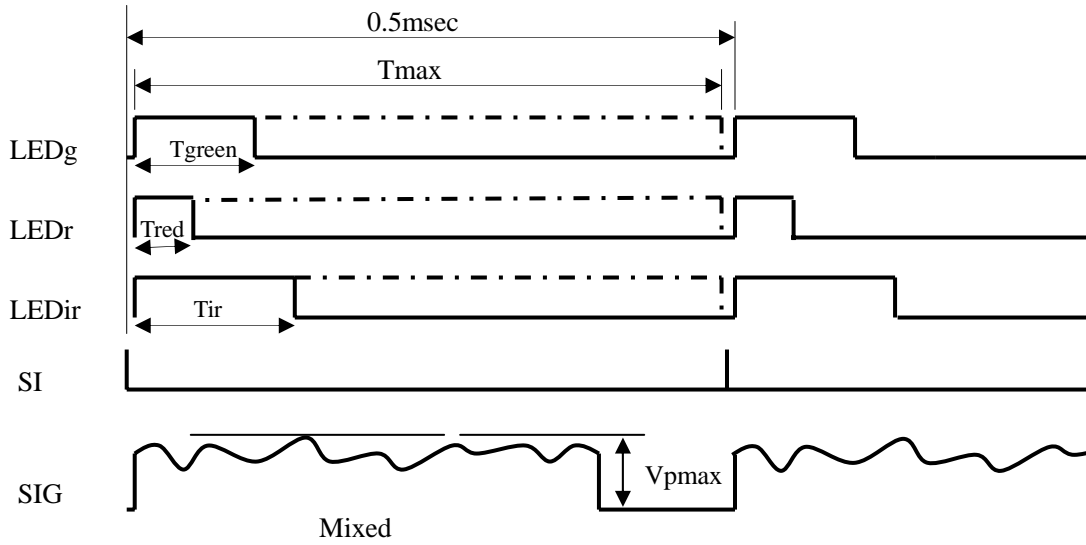


Refer the adjustment flow chart at Figure 6.

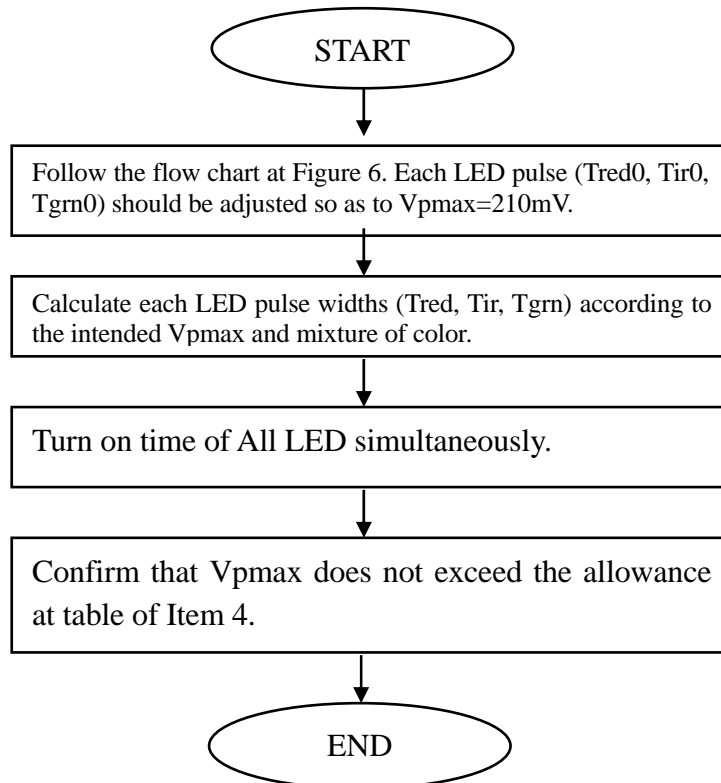
**Figure 5. Timing Diagram with single LED**  
(This is the SHEC shipping test condition.)



**Figure 6. Flow chart for single-LED Adjustment**

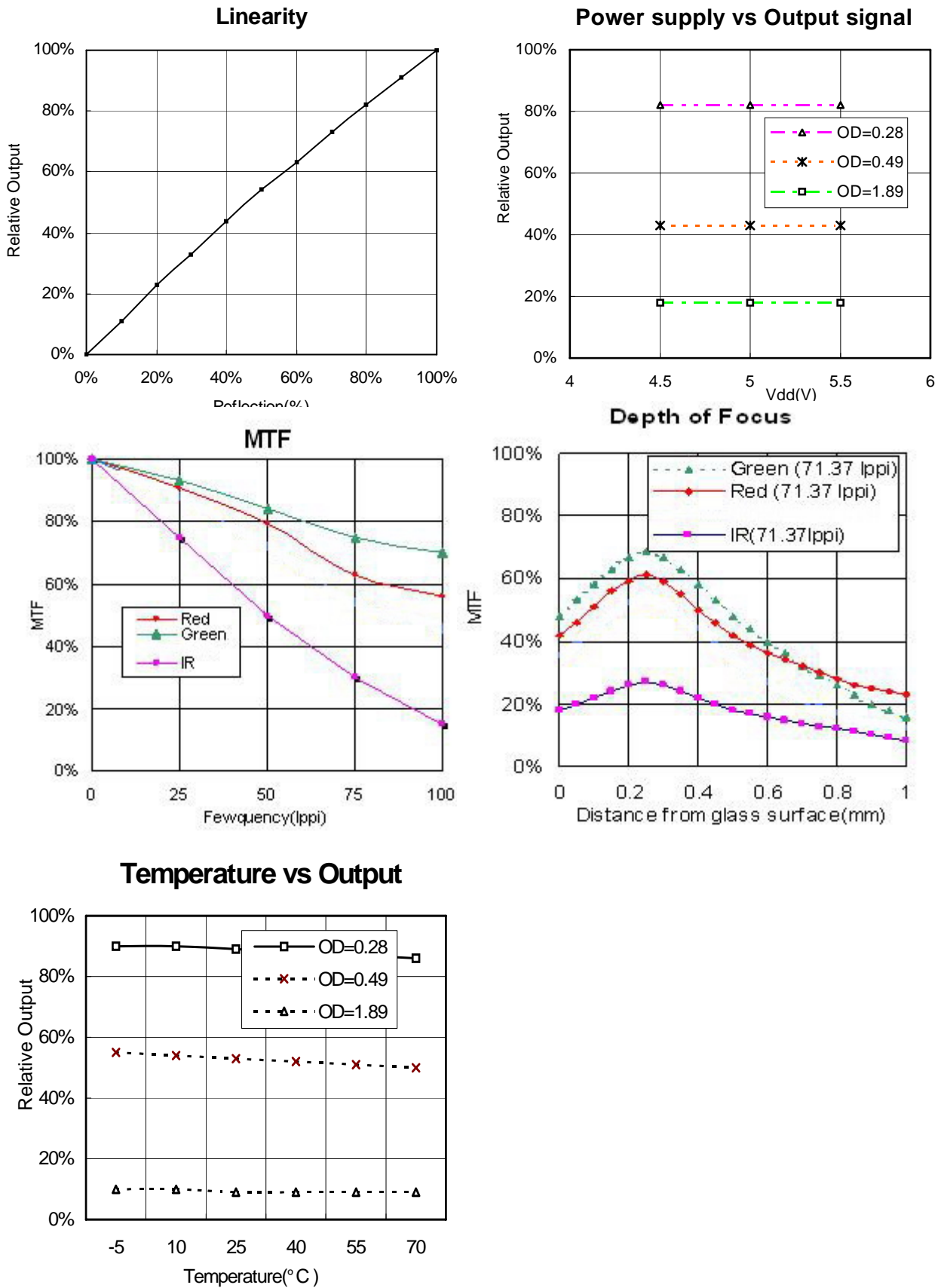


**Figure 7. Timing Diagram with multi-LED**  
(This is the SHEC shipping test condition.)

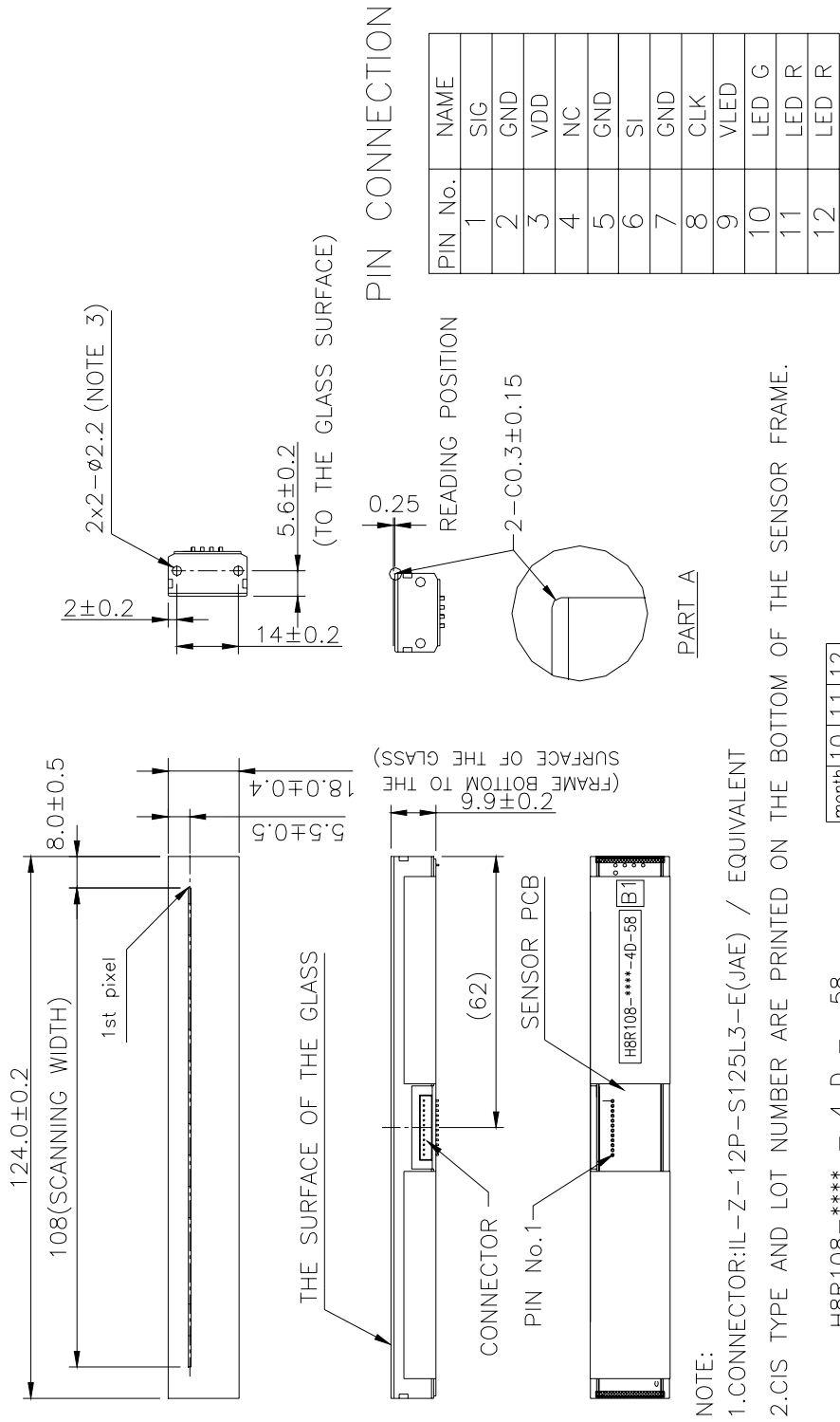


**Figure 8. Flow chart for multi-LED Adjustment**

**Figure 9. Typical Performance Curve**  
Unless otherwise specified, Ta=25°C



**Figure 1 Dimensions**



Mass Production Sample

OUTLINE : Additional Page

PART A

- NOTE:
- 1.CONNCTOR:IL-Z-12P-S125L3-E(JAE) / EQUIVALENT
  - 2.CIS TYPE AND LOT NUMBER ARE PRINTED ON THE BOTTOM OF THE SENSOR FRAME.

month	10	11	12
	A	B	D

H8R108-\*\*\*\* - 4 D - 58  
(CIS TYPE)(2004)(OCT)(1~99999)

- 3.WHEN ATTACHING THE HOLDERS TO THE CIS, USE M2.5(M2.6) TAPPING SCREWS. THE INSERTION MAX 6.0(HOLES DEPTH 6.5)
- 4.COVER-GLASS SHOULD NOT PROTRUDE FROM BOTH SIDE EDGE OF FRAME.